



- ▶ **Ideal for hand or foot operation**
- ▶ **Tough flexible cover**
- ▶ **Choice of colours (others available)**
- ▶ **Change over contact variant**
- ▶ **Available with plastic base plates for added stability or permanent fixing or additionally with anti-slip rubber or foam pads**

Specifications	
Standards/approvals	Low voltage directive 2014/35/EU
Degree of protection	EN 60529 IP67 (IP68 upon request)
Connection method	Stripped cable cores or connector of your choice
Electrical rating	SPST N/O, SPST N/C, SPCO
Contact configuration	See table below
Pressure range	n/a
Operating temperature range	-5°C to +40°C
Body material	Thermoplastic
Weight	0.25 kg
Additional information	250V AC versions available upon request Non mounting hole versions supplied with foam pad



Dimensions

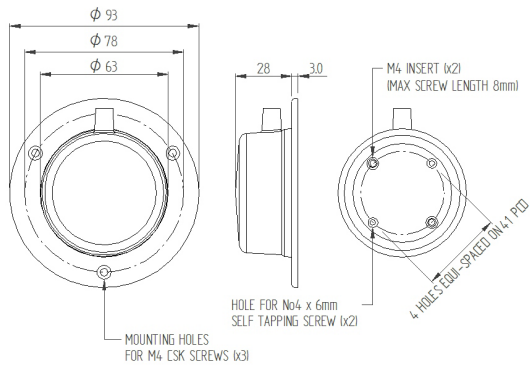



Ordering information

(Please use the characters in the chart below to create your product code)

Sample Code 6240 - A C A A - A A 00

Colour Option

A	Black
B	Grey
C	White
D	Red
F	Green

Mounting option

C	No mounting plate but with M4 inserts fitted
D	Grey plastic plate with mounting holes
E	Grey plastic plate without mounting holes
F	Black plastic plate with mounting holes
G	Black plastic plate without mounting holes
H	Chrome plated plastic plate with mounting holes
J	Chrome plated plastic plate without mounting
Z	No mounting plastic or inserts supplied

Contact configuration

A	SPST N/O
B	SPST N/C
C	SPCO (3-core cable minimum)

Cable length

A	2m
B	3m
C	5m
D	10m

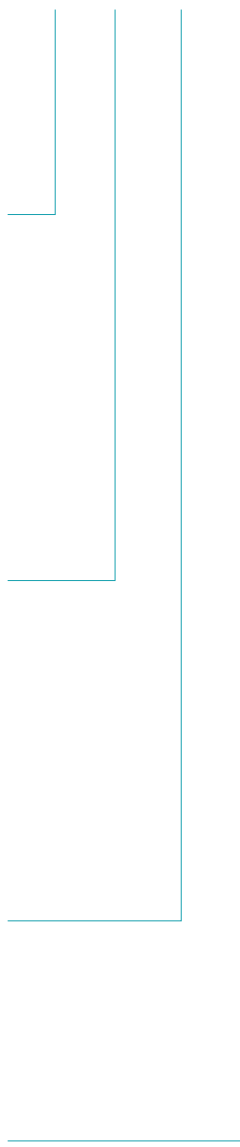

If you require a customized solution for your program contact our sales team.



Ordering information

(Please use the characters in the chart below to create your product code)

Sample Code 6240 - A C A A - A A 00

IP40 cordset rating

A	3A 24V AC/DC, 2-core black cable, silver contacts
C	0.1A 24V AC/DC, 2-core black cable, gold contacts
D	3A 24V AC/DC, 3-core black cable, silver contacts
F	0.1A 24V AC/DC, 3-core black cable, gold contacts
Z	No option chosen

IPX7 cordset electrical rating

A	3A 24V AC/DC, 2-core black cable, silver contacts
C	0.1A 24V AC/DC, 2-core black cable, gold contacts
D	3A 24V AC/DC, 3-core black cable, silver contacts
F	0.1A 24V AC/DC, 3-core black cable, gold contacts
Z	No option chosen

Stock models : 6240-AFAA-ZA00
 6240-DFAA-ZA00

Part Number	Description
6202-0001	Single Black RAL 9005 guard
6202-0002	Single Grey RAL 7035 guard
6202-0003	Twin Grey RAL 7035 guard



If you require a customized solution for your program contact our sales team.