



- ▶ **Powder coated body/base die cast aluminium, its toughness and modest cost make it ideal for OEM applications**
- ▶ **Optional powder coated mild steel guard**
- ▶ **Pneumatic version available, please refer to Airswitching section for details**
- ▶ **Customer colours and logos available on request**
- ▶ **Ideal for remote switching in harsh environmental conditions where durability is required**

Specifications	
Standards/approvals	footswitch: low voltage directive 2006(95/EC, EN 60950 microswitch: EN 61058-1, EN 61058
Degree of protection	EN 60529 IPX2, IPX7 (IPX8 upon request)
Connection method	Stripped cable cores or connector of your choice
Electrical rating	See table below
Contact configuration	See table below
Operating temperature range	-5° C to + 40° C
Body material	Die cast aluminium
Weight	See table below
Additional information	Cordset variations of each standard option are available (6254-DO and DA versions can be build with cordset)

6254 GENERAL INDUSTRIAL FOOTSWITCH RANGE



Dimensions

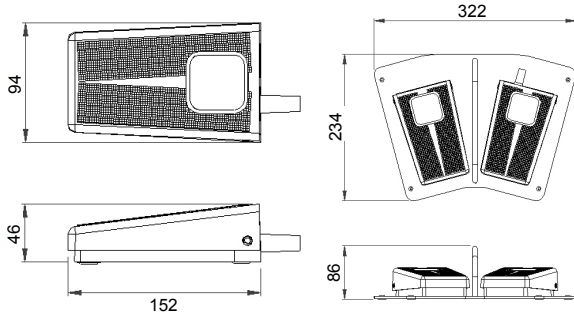

Order information

Stock models

Model No	6254-CT	6254-NT	6254-CC	6254-DO	6254-DA	6254-WO
Weight approx.	0,475 Kg	0,475 Kg	0,475 Kg	0,475 Kg	0,525 KG	0,525 Kg
Optional black guard	18 SWG mild steel, powder coated					
No. of poles	SPCO	SPCO	SPCO	DPCO	DPCO stag- gered	SPST N/O
Cable	Terminal block	Push on ter- minal	3-core + earth	Terminal block	Terminal block	3-core + earth
Cable length stand- ard	n/a	n/a	2 m	n/a	n/a	2 m
Cable O/D (mm)	n/a	n/a	7,5 (nom.)	n/a	n/a	6,8 (nom.)
Current rating @ 250V AC	10A	25A	6 (3)A	6 (3)A	6 (3)A	6 (1,5)A
Internal switch mod- ule	IPX2	IPX2	IPX2	IPX2	IPX2	IPX7

Accessories

Part Number	Description
6202-0001	Single Black, RAL 9005 guard
6202-0002	Single Grey, RAL 7035 guard

